

T-Start Detection and Activation Devices (with Accessories)

SKU(s): 102 to 106



T-Start Models:

- **T_(72°)-Start**
- **T_(110°)-Start**
- **T_(Manual)-Start**

Accessories:

- **Detection Circuit Junction Box**
- **Protective Cap**

Table of Contents

1. Introduction.....	2
2. General.....	2
3. Design & Operation	2
3.1 Design.....	2
3.2 Operation.....	2
3.3 Modification	3
4. Product Range and Technical Characteristics.....	4
4.1 Product Range.....	4
4.2 Technical Characteristics.....	4
5. Applications.....	5
6. Limitations of Use	5
7. Installation & Wiring	6
8. Safety Requirements.....	6
9. Service Life & Maintenance.....	6
10. Components & Accessories	7
11. Packaging.....	7
12. Disclaimer	7
13. Warranty.....	7
14. Contact Information	7

1. Introduction

This document represents a user manual which provides technical information on the design, operation, and maintenance of the T-Start models. It also includes warranty information.

2. General

The T-Start model device is a unique autonomous thermal activation and detection device that allows for the detection of a fire and the activation a powder, aerosol or gaseous fire suppression system. Also, the device has features such as providing a signal to a fire panel and an additional output to shut down electrical equipment, or to activate alarms (depend on modifications).

The T-Start partnered with the specially designed **Detection Circuit Junction Box**, provides an intrinsically safe interface, and can be used as a safety sensor in hazardous areas.

The T-Start can also be used as a thermal detector with a fixed temperature reading, and can be connected to an existing fire detection circuit or fire-indicating panel.

3. Design & Operation

3.1 Design

The T-Start device is designed for the autonomous activation of a fire suppression system. No external power supply is required. There are two base models of T-start; the first model is for automatic activation, and the second one is for manual activation.

3.2 Operation

When the heat-sensitive element (7) reaches its rated temperature, a spring-loaded rod (10) mounted inside a nosepiece (9) is released. The spring moves the cylindrical shape magnets (4), mounted on the rod (10), through an induction coil (12). The induction coil generates an electric impulse. The impulse is transmitted to the electrical terminals (2) and further to the aerosol or powder fire extinguishers.

Figure 1: Schematic diagram of the T-Start (automatic model)

1	Base
2	Electric Terminals
3	RF & EMI Shielded Protective Cover
4	Magnets
5	Housing (Made from High-Temperature Plastic)
6	Compression Spring
7	Heat Sensitive Lock (Made from a Shape Memory Alloy)
8	Safety Pin
9	Bronze Nose Piece
10	Bronze Rod
11	Frame of Reel
12	Electromagnetic Coil
13	Diode

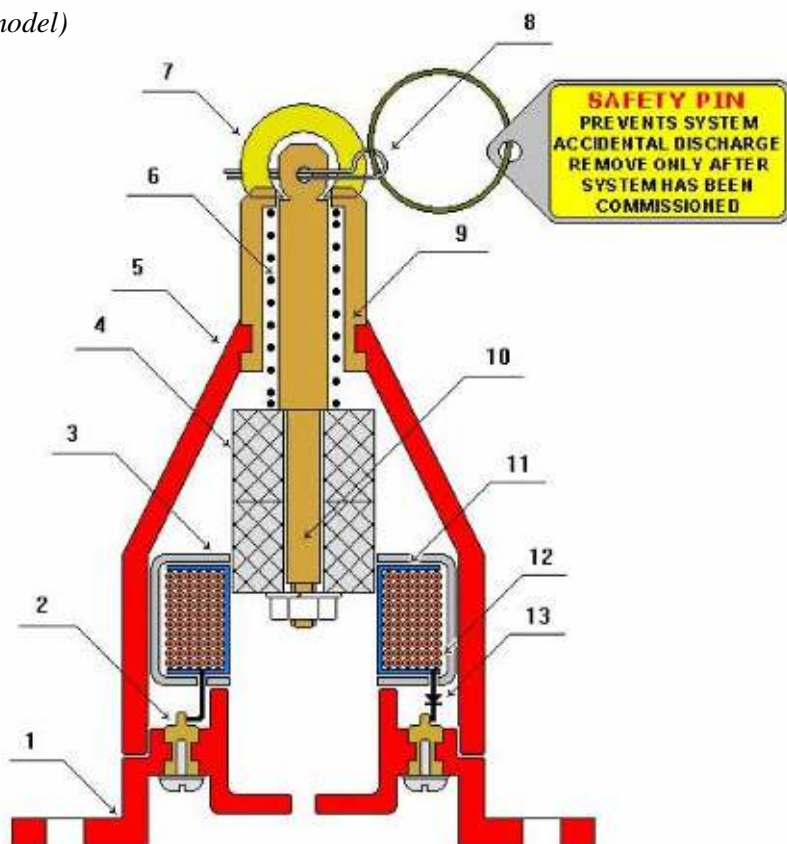

T_(M)-Start – A T-Start device which is designed for manual activation of a fire suppression system. It operates as follows: in a case of a fire, the split pin (6) is removed from the device by manually pulling the ring (5). This action releases a spring-loaded pin (9). A further sequence of events is similar to that for automatic T-Start with a heat-sensitive element.

Figure 2: Schematic diagram of T_(M)-Start (Manual Operation)

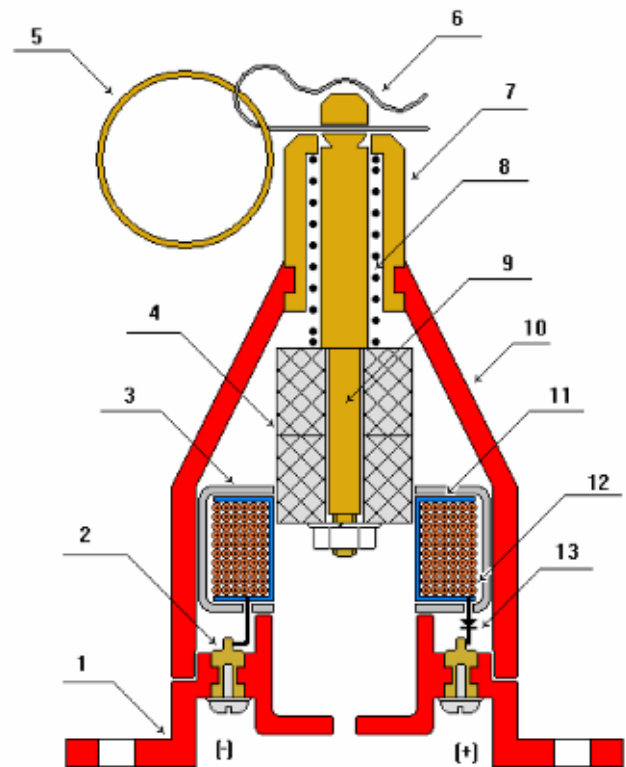

1	Base
2	Electric Terminals
3	RF & EMI Shielded Protective Cover
4	Magnets
5	Pull Ring
6	Split Ring
7	Bronze Nose Piece
8	Compression Spring
9	Bronze Rod
10	Housing (Made from High-Temperature Withstanding Plastic)
11	Frame of Reel
12	Electromagnetic Coil
13	Diode

3.3 Modification

A T-Start device can have three different modifications that make it easier to adapt it for use in different applications. These three modifications can be combined according to the design requirement.

First Modification

The T-start can be used in a harsh environment. For this application, the device should be installed with a **Protective Cup** (see Figure 3 below). Figure 3: Schematic diagram of a T-Start with a **Protective Cup**

1	Base
2	Electric Terminals
3	RF & EMI Shielded Protective Cover
4	Magnets
5	Compression Spring
6	Bronze Rod
7	Bronze Nose Piece
8	Heat Sensitive Lock (Made from a Shape Memory Alloy)
9	Protective Cup
10	'O' Ring
11	Bushing
12	Housing (Made from High-Temperature Plastic)
13	Frame of Reel
14	Electromagnetic Coil

Attention: The **Protective Cup** will reduce the sensitivity of the heat-sensitive element, and as a result, the activation time increases.

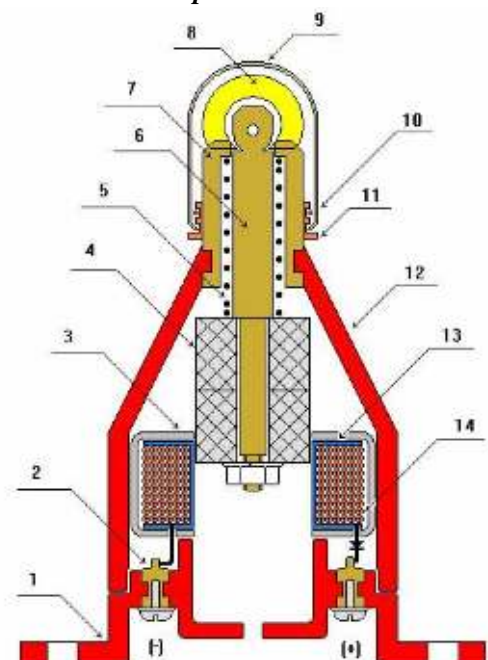

Second Modification

For most applications, it is very convenient to use activation devices as well as a thermal detector. This allows for the connecting of devices to an existing fire detection line, or directly to fire panel. This feature is available with the specially designed **Detection Circuit Junction Box** (see *Figure 4* below).

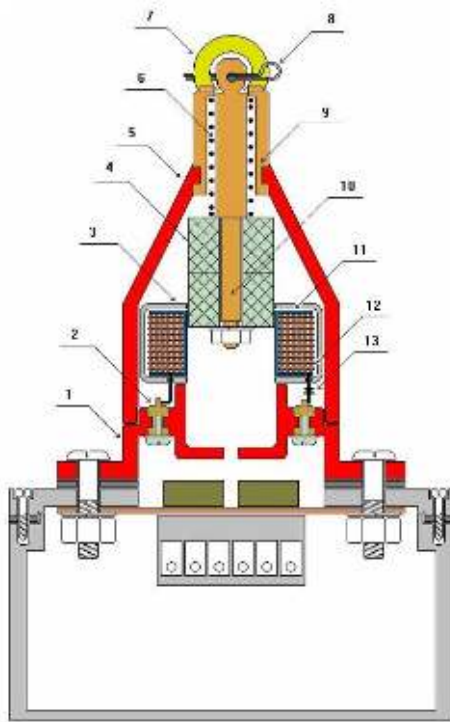

Figure 4: Schematic diagram of a T-Start with a Detection Circuit Junction Box

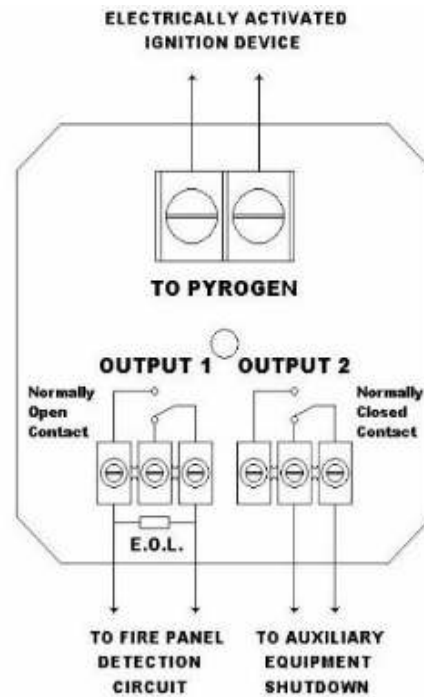

Figure 5: Electrical Connection Diagram (T-Start with Junction Box)

Third Modification

The **Detection Circuit Junction Box** connected to a fire panel through an intrinsically safe detection circuit allows for the usage of this modification of T-start in hazardous areas. For more information, please contact Artek using the Contact Us page on our website, or via the email listed at the end of this manual.

4. Product Range and Technical Characteristics

4.1 Product Range

The T-start devices come in three different models. Two of the models operate automatically, similar to the thermal detectors with rated temperatures. The third model is designed for manual activation of the fire extinguishers.

The following models are available:

- Model **T_(72°)-Start** (Standard Application)
- Model **T_(110°)-Start** (Suitable for Motor Rooms and Tracks)
- Model **T_(M)-Start** (Designed for Manual Activation)

Attention: All models can be supplied with a protective cup and junction boxes.

4.2 Technical Characteristics

4.2.1 Dimensions and Mass (Protective Cup and Junction Box Excluding)

Length	< 85mm
Diameter	< 65mm
Total Mass	< 0.2kg

4.2.2 Operation Temperature Ranges

T_(72°)-Start	-60 to +55 °C
T_(110°)-Start	-60 to +95 °C
T_(M)-Start	-60 to +95 °C

4.2.3 Rated Activation Temperature

T_(72°)-Start	+72°C ±5°C
T_(110°)-Start	+110°C ±5°C

4.2.4 Activation Time

Activation time depends on the model of the T-Start, initial ambient temperature and the temperature increase rate. The temperature increase rates (TIR) of **3°C/min** and **30°C/min** have been selected as standard. For TIR 30°C/min, activation time should be in the range of 58 – 144 seconds, and for TIR 3°C/min - in the range of 580–960 seconds.

Table 1: Activation times test results for the T_(72°)-Start and T_(110°)-Start

T(xx°)-Start Model	Initial Ambient Air Temp. (°C)	TIR 30°C/min		TIR 3°C/min	
		Maximum Time Delay (sec)	Minimum Time Delay (sec)	Maximum Time Delay (sec)	Minimum Time Delay (sec)
T(72°)-Start	35 °C	93 sec	85 sec	740 sec	724 sec
T(110°)-Start	70 °C	137 sec	125 sec	950 sec	937 sec

Figure 6: Electrical Diagram of the T-Start

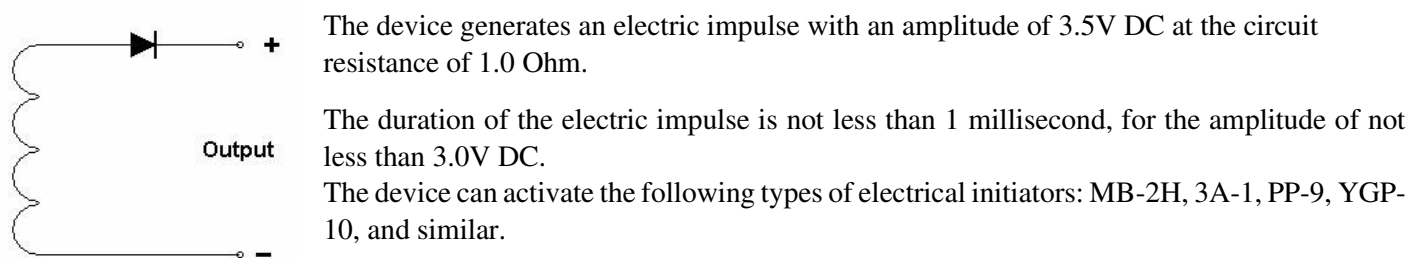

5. Applications

Industrial

Electrical substations, high voltage transformers, transportation tunnels supporting infrastructures, flammable material storage facilities, broadband mobile cellular communication systems, warehouses, etc.

Electrical Cabinet

Power factor correction cabinets, motor control cabinets, process automation control cabinets, high current DC converter cabinets, high voltage cabinets transformer cabinets, uninterrupted power supplies, electrical enclosures electronic control boxes

Mining

Conveyer lines, tunnels, hazardous areas, underground electrical substations, high voltage transformers, mobile equipment, generator & compressor rooms, cable trays, etc.

Automotive and Mobile Equipment

Buses & coaches, trucks, off-road vehicles, earth-moving equipment, mining mobile equipment, farming equipment, armoured vehicles, cars & SUVs, rolling stocks (rail-vehicles), marine, domestic (garage), etc.

6. Limitations of Use

1. Volume protected by one device shall not exceed 18m³.
2. The dimensions of a protected area shall not exceed:
 - Height - 3.0 meters
 - Width - 2.4 meters
 - Length - 2.5 meters
3. The device should be located in the middle of the protected area, at 100-150 mm below the ceiling.
4. The device is capable of sustaining vibrations from 0.5 to 200 Hertz, with an acceleration of 4g.
5. The device is capable of sustaining impacts of up to 4g-force, of 2 to 50 milliseconds duration.
6. The device is suitable for application in hazardous areas of 2ExeIIT6 category.

7. The spark-less design modification of the T-start with Junction Box makes it suitable for hazardous areas of POExiaI category.
8. Maximum relative humidity – 98% (no condensation).

7. Installation & Wiring

1. One circuit shall have not more than 10 devices.
2. The length of the cable between two devices in a loop shall not exceed 3 meters.
3. The devices shall be connected in parallel. The normal polarity of “+” to “+” shall be observed.
4. The device can be used in high density electromagnetic and high-frequency energy zones.
5. Activation cables shall be fire-resistant with copper conductors. A cross-section area of each conductor should not be less than 1 mm² or 0.5 mm² if a multiple core cable is used.
6. If the connection cable is passing through a high-frequency energy zone, such as a two-way radio, a sonar etc, the cable should be screened.
7. If the connection cable is passing through the electric magnetic fields of high density, such as high voltage transformers in power substations or cable tunnels, the cable should be enclosed in a steel conduit.
8. Cable screen and steel conduit shall be grounded in accordance with the standard requirements.
9. If there is a likelihood of any mechanical damage the cable should be enclosed into a plastic or metal conduit.

8. Safety Requirements

1. The device is fire safe.
2. The device shall be installed and maintained in accordance with its design requirements and technical specifications.
3. Only authorized personnel can install, re-set and service the device.
4. The device shall only be used as intended - for activation of fire suppression systems.
5. The attached safety pin shall be in its place during any installation, maintenance or service work in the area to prevent an accidental discharge of the fire suppression system.
Attention: Before reinserting the safety pin all activation wires must be disconnected from the canisters. All electrical circuits must be electrically isolated. Failure to do so may result in an unwanted spurious discharge of the fire extinguishing system.
6. The heat-sensitive element shall be reliably fixed into its position in the device.
7. All screws on electrical terminals shall have spring washers.
8. The device should be attached to an appropriate junction box to ensure proper cable connections.
9. The device is incapable of generating the electric impulses at levels dangerous for humans or animals.
10. The connecting of the cable to the extinguishing units shall always be the last wiring procedure.
11. **After the system has been commissioned to remove the safety pin** (protective copper cup can be installed if required after this) **to ensure the system is left in operable condition.** Before removing the pin ensure the heat-sensitive lock (6) is firmly attached to the bronze rod (10).
12. To avoid the dropping of the protective copper cup please bend the edge of the cup inside the bushing groove in two opposite places.

9. Service Life & Maintenance

1. The device maintenance is free. The reliability of the device is >50,000 hours under normal ambient conditions. The service life of the device is 10 years.
2. If a device is damaged or exposed to a fire, it shall not be re-used.
3. Should the heat-sensitive element be damaged, the device shall not be used.
4. Should the device be set off by an accident, it shall be returned to Artek for repairing. It shall not be re-used as the heat-sensitive element might have been damaged or overheated.

10. Components & Accessories

Components:

- T-Start Device
- User Guide and Manual (one for ten devices; more can be printed per request)

Accessories:

- Detection Circuit Junction Box
- Protective Copper Cup (for dust and water-splash environments)

11. Packaging

- The devices are placed in a cardboard box. There are 10 devices per box.
- Inside the box, the devices are placed in rows with a space between the devices filled with a carton packaging material.
- A packaging list, a user guide and manual are enclosed in a plastic envelope and placed onto the top row (one envelope per every ten devices; additional manuals can be printed per request).
- The following labels will be attached to each cardboard box with the devices:
 - Fragile
 - Keep in a dry place
 - Do not drop
 - Delicate equipment

12. Disclaimer

This manual is for use by trained and authorized personnel only. The information contained in the document is protected by patents. All rights are reserved. Unauthorized copying of this manual and its contents is strictly forbidden. The document is accurate at the time of issue, however, is subject to changes to its content from time to time.

13. Warranty

Artek claims that **T-Start** device has undergone quality control and has no defects. Warranty applies for one year from the date of purchase.

This limited warranty does not cover any **T-Start** device that has been damaged or rendered defective as a result of an accident, misuse or abuse, or serviced by anyone other than authorized service person, or by using the parts that are not manufactured or sold specifically for this device or any modification done without written permission of the manufacturer.

14. Contact Information

Artek Engineering Pty Ltd - ABN 55 102 571 095

Website: artek.net.au

Email: administration@artek.net.au